



# POLYAIR

## TECHNICAL PRODUCT SPECIFICATION

Revision No	1	Customer: General Specification
Issue Date:	2-Aug-2022	
Manufactured	Toronto ON	Description: 3/16"X8"X11.5" BUBBLE POUCHES
Work Center	Pouch Line	W/1" LIP&TAPE
Part Number	PCH EZ8X11.5	

### Line Diagram

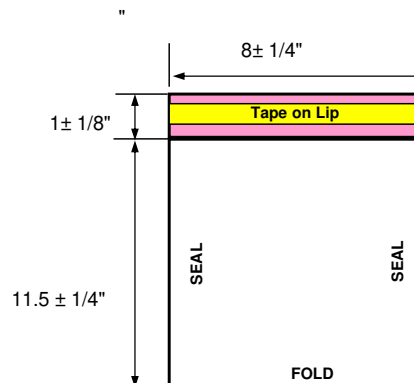

(A) FINISHED PRODUCT			
Dimensions	Min	Target	Max
Opening (inch)	7.750	8.000	8.250
Depth (inch)	11.250	11.500	11.750
Lip (inch)	0.875	1.0	1.125
With Tape			
PACKAGING			
Quantity	350	Pcs/ Carton	

### (B) PHYSICAL PROPERTIES DESCRIPTION

PROPERTY	RESULT	
	Nominal Values	UoM
NOMINAL CELL HEIGHT	3/16	inches
DEFLATION	< 5	%
MINIMUM TEMPERATURE	-50 (°C)	-58 (°F)
MAXIMUM TEMPERATURE	80 (°C)	176 (°F)
RESISTANCE TO REDUCED PRESSURE (ASTM D6653)	< 10	%
MATERIAL TYPE	#4 -LDPE	
RECYCLED CONTENT	up to 20	%
MELTING POINT	137 (°C)	275 (°F)

Durabubble is made from a blend of Polyethylenes. This product is recyclable where facilities exist and the material identification number is # 4

Sore drop off recyclable. May not be recyclable in your area



The technical information, suggested uses and applications presented are made without charge and are believed to be reliable; however, POLYAIR disclaims responsibility for results of use of this information. POLYAIR makes no warranties, either express or implied, concerning our materials, including any statements or suggestions as being inducements. All users should rely on their own test in determining suitability.

This product data sheet is effective 2022-08-02 and supersedes all previously published data.

POLYAIR PACKAGING(Divison of Intertape Polymer Group-An IPG Company)

Quality Assurance Department  
 Corporate Headquarters: 330 Humberline Drive, Toronto, ON M9W 1R5  
 PHONE: 800-668-4886; FAX: 416-679-6610