

PRODUCT INFORMATION SHEET

Rev. 2021-01-04

Item #

Product #

70-24900

959-115



Plastipak Industries Inc.
1-800-387-7452
www.plastipak.ca

Quality. Service. Innovation.

PRODUCT INFORMATION

Description	959 ml - 32 US fl.oz Base
Pack size	500
Color	CLEAR
Shape	Round
Special feature	
Family	116 mm
Brimful volume	1031 ml / 34,9 US fl. oz

FORMING PROCESS INFORMATION

Forming process	Thermoforming
Material	Food grade PP
Stock colors	Clear



DECORATION PROCESS INFORMATION

Decoration options	HD Printing
Print area	
Sidewall	321 mm x 100 mm 12,6" x 3,9"
IML or S/S die line	Not applicable

COMPATIBLE PRODUCTS

See fit matrix for the 116 mm family

PACKAGING INFORMATION

Box reference #	P6453		
Stacks per box	20		
Parts per stack	25		
Parts box	500		
Stack orientation	Vertical		
Ext. box dims.	Length	601 mm	23,7"
	Width	491 mm	19,3"
	Height	466 mm	18,3"
External box volume	0,14 cu. m.	4,86 cu. ft.	
Full box weight	10,4 kg	22,9 lbs	

PART DRAWING

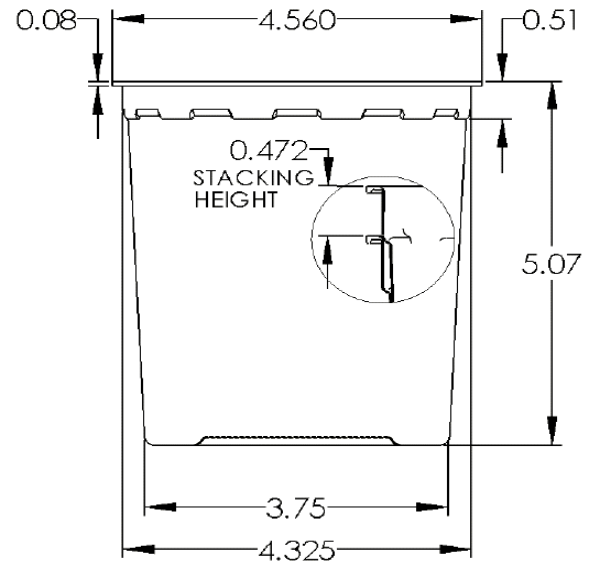

Unit part weight **17,9 g**

Notes Dimensional tolerance: +/- 0,01"
Weight tolerance: +/- 3%

OPTIMIZED PALLET CONFIGURATION

Code

C4L

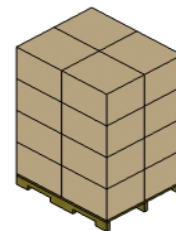

Box / layer	4	Max height	78,9"
Max layers	4	Max Qty	8 000

Layers	Pallet Height in.	Boxes / Pallet	Parts / Pallet
9			
8			
7			
6			
5			
4	78,9	16	8 000
3	60,5	12	6 000
2	42,2	8	4 000