

PRODUCT INFORMATION SHEET

Rev. 2021-01-04

Item #

Product #

133A

9032



Plastipak Industries Inc.
1-800-387-7452
www.plastipak.ca

Quality. Service. Innovation.

PRODUCT INFORMATION

Description	946 ml - 32 US fl.oz Base
Pack size	250
Color	WHITE
Shape	Round
Special feature	
Family	115 mm
Brimful volume	1042 ml / 35,2 US fl. oz

FORMING PROCESS INFORMATION

Forming process	Injection
Material	Food grade PP
Stock colors	Clear, White



DECORATION PROCESS INFORMATION

Decoration options	HD Printing
Print area	
Sidewall	310 mm x 117 mm 12,2" x 4,6"
IML or S/S die line	Not applicable

COMPATIBLE PRODUCTS

See fit matrix for the 115 mm family

PART DRAWING

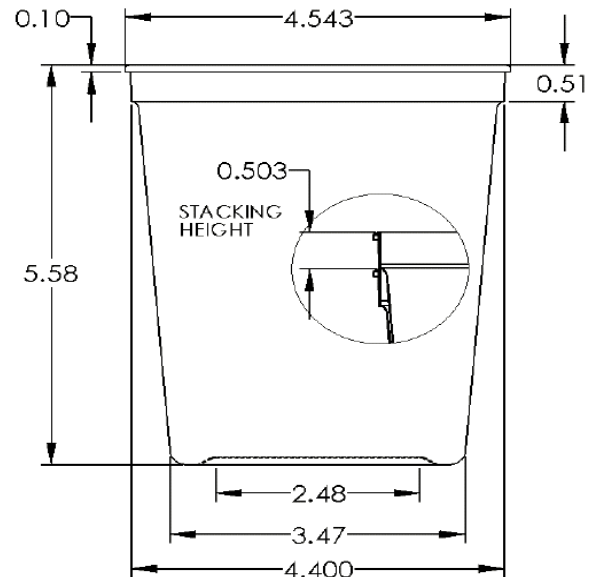

Unit part weight **28,7 g**

Notes Dimensional tolerance: +/- 0,01"
Weight tolerance: +/- 3%

OPTIMIZED PALLET CONFIGURATION

Code

G4L

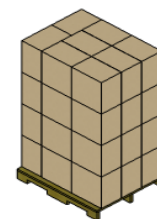

Box / layer	8	Max height	79,7"
Max layers	4	Max Qty	8 000

Layers	Pallet Height in.	Boxes / Pallet	Parts / Pallet
9			
8			
7			
6			
5			
4	79,7	32	8 000
3	61,1	24	6 000
2	42,6	16	4 000

PACKAGING INFORMATION

Box reference #	P6167		
Stacks per box	10		
Parts per stack	25		
Parts box	250		
Stack orientation	Vertical		
Ext. box dims.	Length	587 mm	23,1"
	Width	241 mm	9,5"
	Height	471 mm	18,5"
External box volume	0,07 cu. m.	2,35 cu. ft.	
Full box weight	7,8 kg	17,2 lbs	