

ASQ II Glasswasher by



The *Convenience* of a Carousel with the *Cleaning Power* of a Dishmachine



- **Full load washing - saves power, water, and chemicals**
- **Fast - only 75 seconds per cycle**
- **Rotating spray arm - provides outstanding results**
- **Divided carousel, creates a washing chamber that cleans with a recirculating, high-volume water spray**
- **Load, unload & wash simultaneously**

The ASQ II Glasswasher is revolutionary in both concept and design. It offers the cleaning action of a dishmachine in a carousel system. The carousel is divided into three positions by stainless steel panels. These panels isolate each compartment, controlling the water and washing action of the rotating spray.

With the push of the lever, the manual carousel easily rotates and locks into the next position. While the glasswasher does the cleaning, the bartender can unload spot-free glasses and load the glassware to be washed, efficiently cleaning full loads.

Super Q II Glasswasher

- 120° Final Rinse - allows for effectiveness of Rinse Aids
- Manual Turn Carousel - eliminates washing one glass at a time
- Sustainer Heater - maintains tank temperature
- Built-in Chemical Storage (One Gallon Containers)



Pre-Plumbed Dump Sink and Stainless Steel Drain



Glassware Crossarm with Standard Spray Arm Bearing and Bayonet Pin release.



Separate Stainless Steel Wash and Drain Pumps for Quieter Operation.

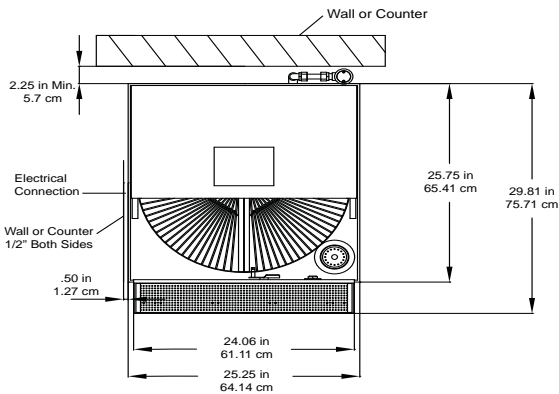

CAUTION:
Electrical and Plumbing connections must be made by a qualified Service Person who will assure that the installation is in compliance with all available federal, state, and local Health, Electrical, Plumbing, and Safety Codes.

NOTE:
All dimensions listed have a tolerance of + or - 1/8" unless otherwise noted.

NOTE:
Manufacturer reserves the right to modify these specifications in compliance with regulatory agencies and manufacturing expediency.

CONNECT TO ELECTRICAL SUPPLY SOURCE
USING 14-12 AWG COPPER WIRE
CIRCUIT PROTECTION: 15 AMP CIRCUIT BREAKER OR FUSE WITH A 15 AMP RATING

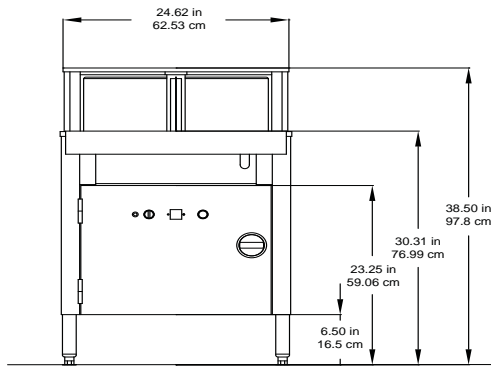

FRONT VIEW

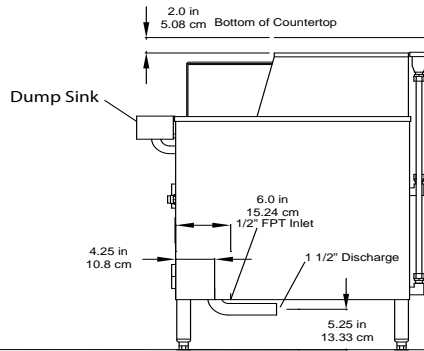

SIDE VIEW



Model ASQ II Specifications

	Model ASQ II
RATED CAPACITY (LOADS PER HOUR)	34
WASH TIME (SECONDS)	45
RINSE TIME (SECONDS)	14
DWELL (SECONDS)	16
TOTAL CYCLE TIME (SECONDS)	75
	43.2 GAL/Hr
WATER TEMPERATURE	120 °F 49 °C
WATER CONSUMPTION	1.27 GAL PER CYCLE 4.8 LITERS PER CYCLE
MOTORS (WASH)	1/3 HP, 3450 RPM
(DRAIN)	.246 KW
HEATER	1/6 HP, 3450 RPM .124 KW 350 W
ELECTRICAL RATINGS	115 VOLTS SINGLE PHASE 7.5 AMP 60 Hz
WATER INLET	1/2" FPT 1.3 CM
DRAIN	1 1/2" O.D. 3.8 CM
HEIGHT (OVERALL)	38 1/2" 97.5 CM
WIDTH (OVERALL)	25 1/4" 64.1 CM
DEPTH (OVERALL)	29.8" 75.7 CM
SHIPPING WEIGHT	288 POUNDS 130.6 Kg
SHIPPING DIMENSIONS	36"L x 36"W x 46"H 91.4 cm x 91.4 cm x 116.8 cm